

AstroSemi™

Incredible Power for Small Body

370W~380W

Monocrystalline PV Module

CHSM60M-HC Series (166)

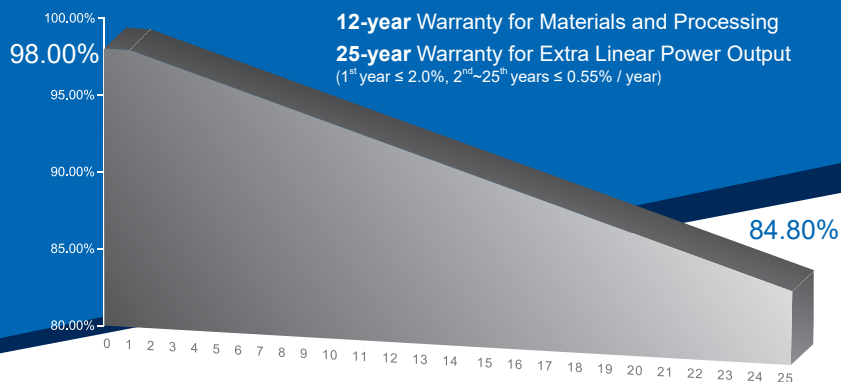
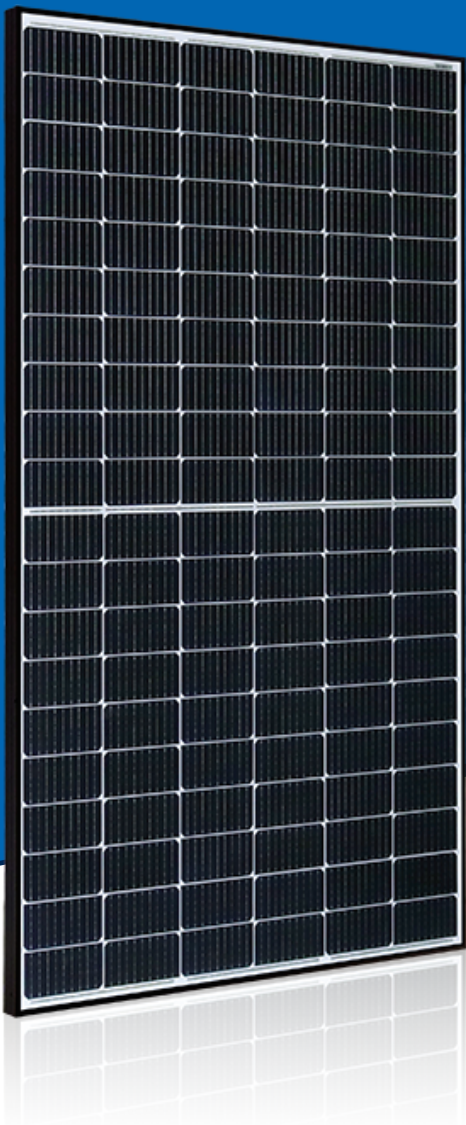

KEY FEATURES

- +5W OUTPUT POSITIVE TOLERANCE**
Guaranteed 0~+5W positive tolerance ensure power output reliability.
- INNOVATIONAL HALF-CELL TECHNOLOGY**
Improve the module output, decrease the risk of micro cracking, enhance the module reliability.
- INNOVATIVE PERC CELL TECHNOLOGY**
Excellent cell efficiency and output.
- REDUCE SHADOW LOSS**
Effectively reduce the effect of shading on the module surface.
- REDUCE INTERNAL MISMATCH LOSS**
Reduce mismatch loss and improve output.
- PASSED HAIL TEST**
Certified to hail resistance: ice ball size (d=25mm) and ice ball velocity (v=23m/s).
- Anti PID RESISTANCE**
Excellent PID resistance at 96 hours (@85°C /85%) test, and also can be improved to meet higher standards for the particularly harsh environment.

COMPREHENSIVE CERTIFICATES



First solar company which passed the TUV Nord IEC/TS 62941 certification audit.

For Global Market



ASTRONERGY
A CHNT COMPANY

ELECTRICAL SPECIFICATIONS

STC rated output (P_{mpp})*	370 Wp	375 Wp	380 Wp
Rated voltage (V_{mpp}) at STC	33.98 V	34.28 V	34.51 V
Rated current (I_{mpp}) at STC	10.89 A	10.94 A	11.01 A
Open circuit voltage (V_{oc}) at STC	40.75 V	41.05 V	41.34 V
Short circuit current (I_{sc}) at STC	11.35 A	11.42 A	11.49 A
Module efficiency	20.0%	20.3%	20.5%
Rated output (P_{mpp}) at NMOT	275.9 Wp	279.6 Wp	283.4 Wp
Rated voltage (V_{mpp}) at NMOT	31.68 V	31.96 V	32.18 V
Rated current (I_{mpp}) at NMOT	8.71 A	8.75 A	8.81 A
Open circuit voltage (V_{oc}) at NMOT	38.31 V	38.59 V	38.87 V
Short circuit current (I_{sc}) at NMOT	9.13 A	9.19 A	9.24 A
Temperature coefficient (P_{mpp})	- 0.34%/°C		
Temperature coefficient (I_{sc})	+0.04%/°C		
Temperature coefficient (V_{oc})	- 0.27%/°C		
Nominal module operating temperature (NMOT)	44±2°C		
Maximum system voltage (IEC/UL)	1500V _{DC}		
Number of diodes	3		
Junction box IP rating	IP 68		
Maximum series fuse rating	20 A		

STC: Irradiance 1000W/m², Cell Temperature 25°C, AM=1.5
 NMOT: Irradiance 800W/m², Ambient Temperature 20°C, AM=1.5, Wind Speed 1m/s

CURVE

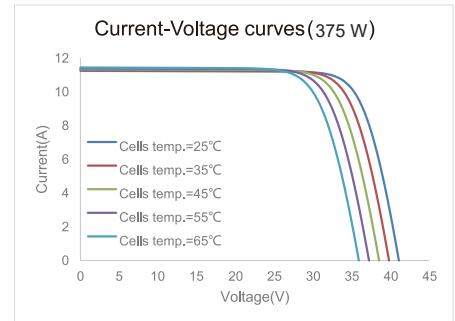
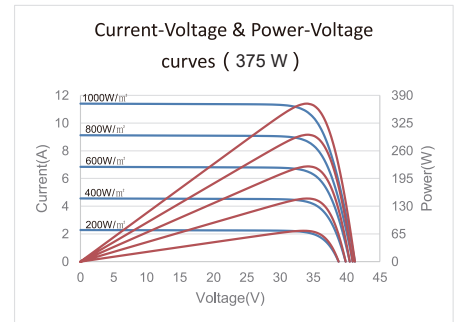

MECHANICAL SPECIFICATIONS

Outer dimensions (L x W x H)	1765 x 1048 x 35 mm
Frame technology	Aluminum, black anodized
Module composition	Glass / EVA / Backsheet (white)
Front glass thickness	3.2 mm
Cable length (IEC/UL)	1200 mm
Cable diameter (IEC/UL)	4 mm ² / 12 AWG
① Maximum mechanical test load	5400 Pa (front) / 2400 Pa (back)
Fire performance (IEC/UL)	Class C (IEC) or Type 4 (UL)
Connector type (IEC/UL)	HCB40

① Refer to Astronergy crystalline installation manual or contact technical department.
 Maximum Mechanical Test Load=1.5×Maximum Mechanical Design Load.

PACKING SPECIFICATIONS

① Weight (module only)	20.0 kg
② Packing unit	31 pcs / box
Weight of packing unit (for 40'HQ container)	661 kg
Number of modules per 40'HQ container	806 pcs

① Tolerance +/- 1.0kg
 ② Subject to sales contract

MODULE DIMENSION DETAILS

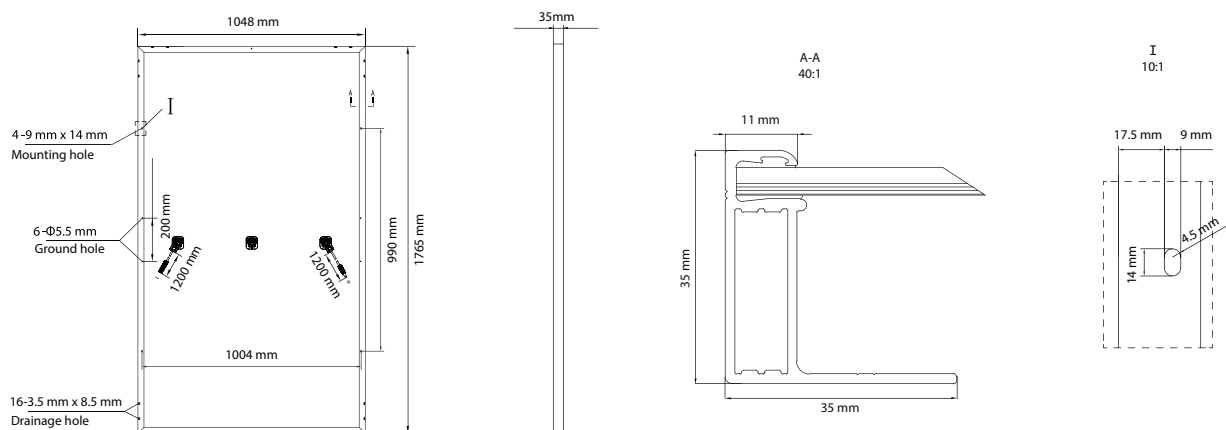

© Chint Solar (Zhejiang) Co., Ltd. Reserves the right of final interpretation. please contact our company to use the latest version for contract.