

Elektrische Nachheizung

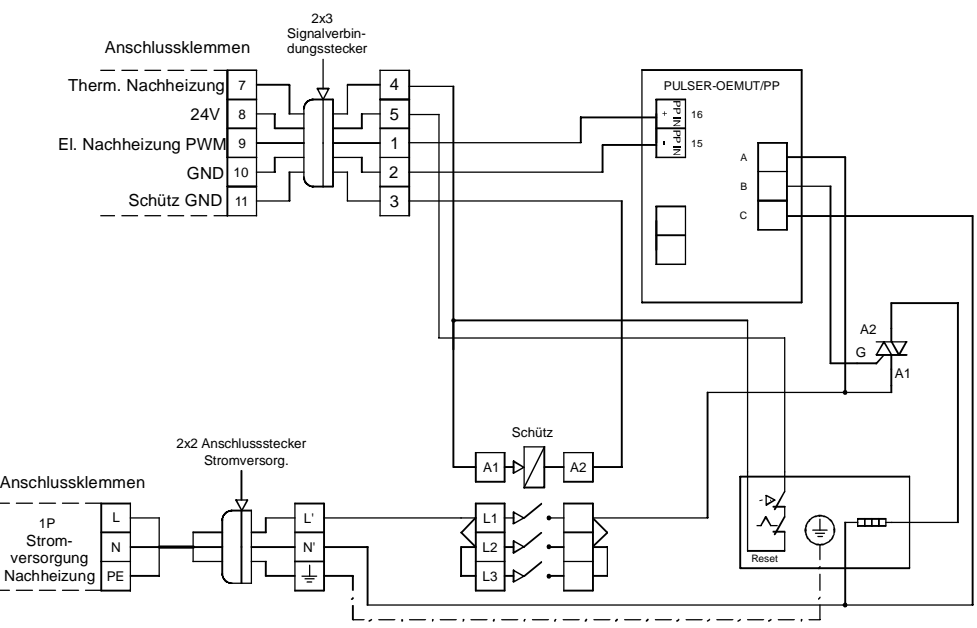

Pumpen

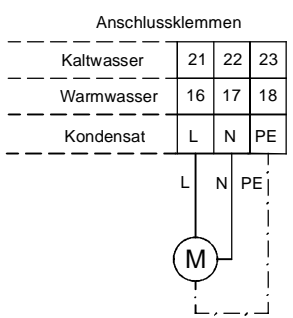

AIR1-BE TOUCH

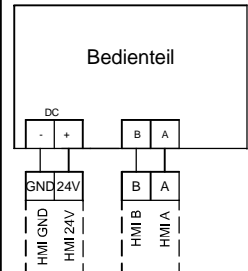

Stromversorgung

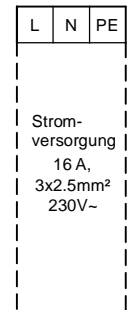

BACNET & MODBUS

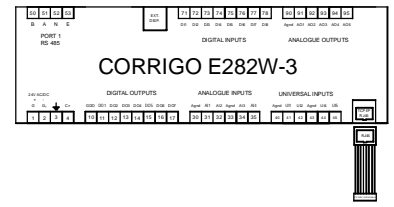

Luftqualitätssensoren

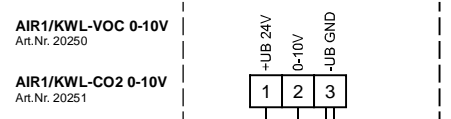
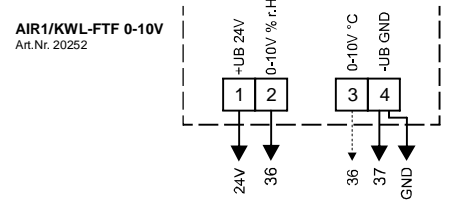

36-37: Luftqualitätssensor 1 oder Temperatur-Sensor (Temperaturausgang AIR1/KWL-FTF 0-10V)

38-39: Luftqualitätssensor 2

40-41: Luftqualitätssensor 3

Air1 CO2 K

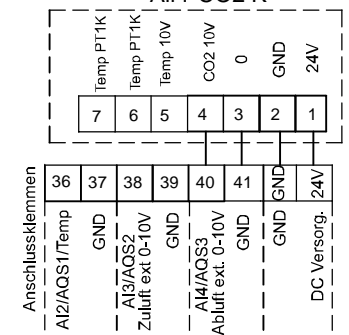

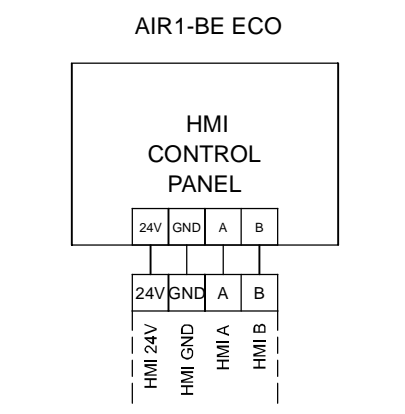
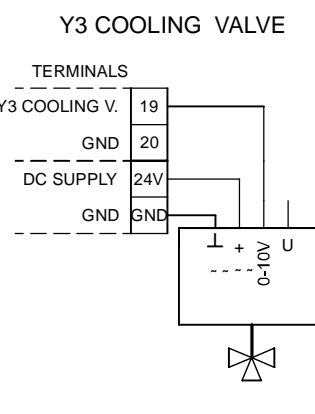
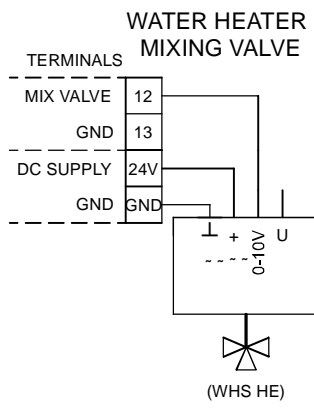
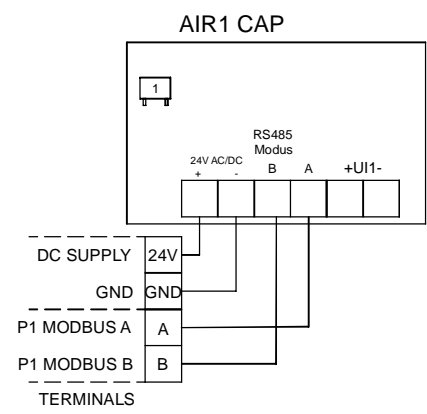
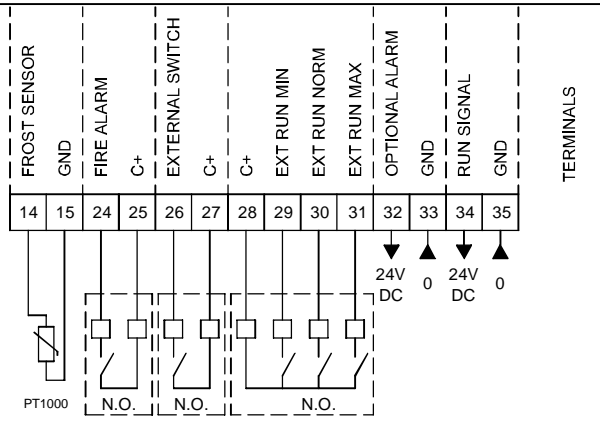

ELECTRICAL AFTER HEATER

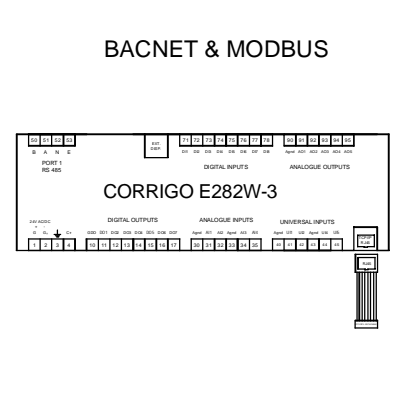
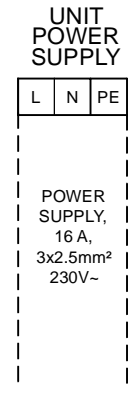
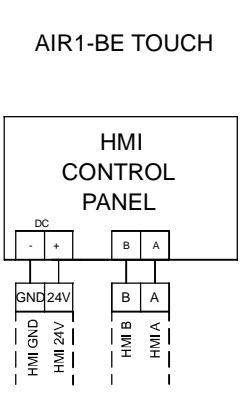
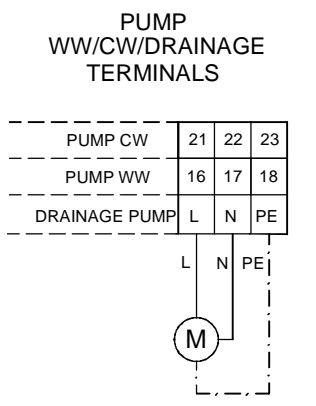
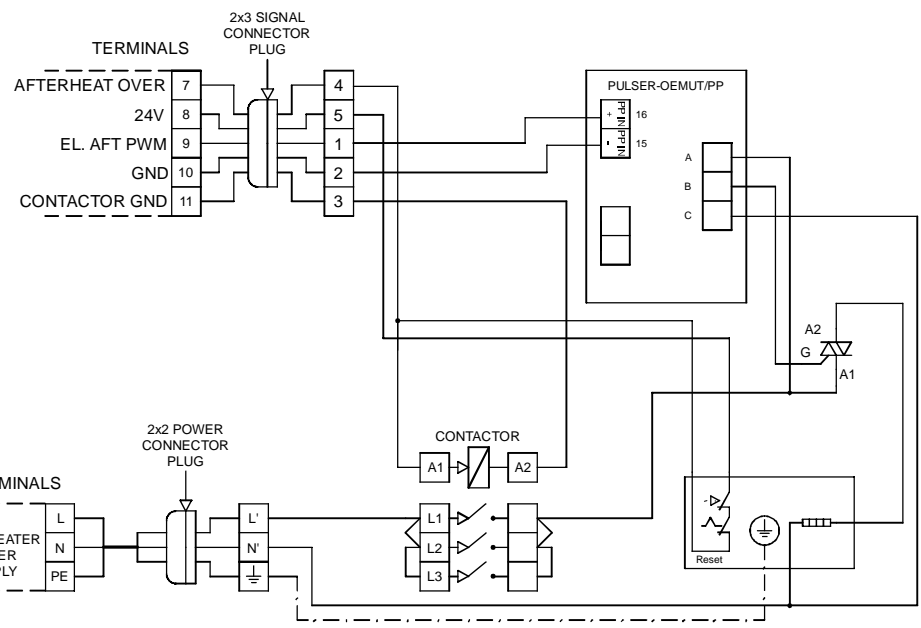

Air Quality Sensors

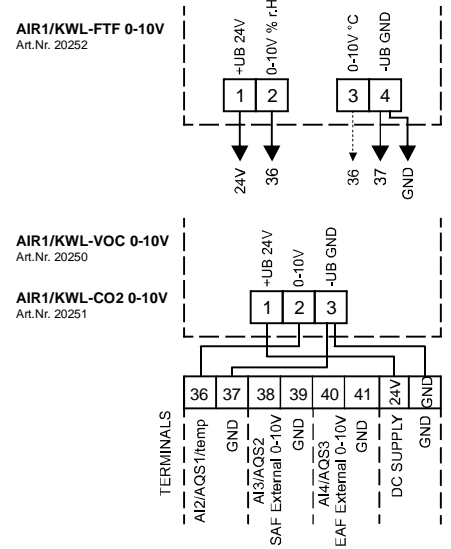

36-37: Air Quality Sensor 1 or temperature sensor (temp output AIR1/KWL-FTF 0-10V)

38-39: Air Quality Sensor 2

40-41: Air Quality Sensor 3

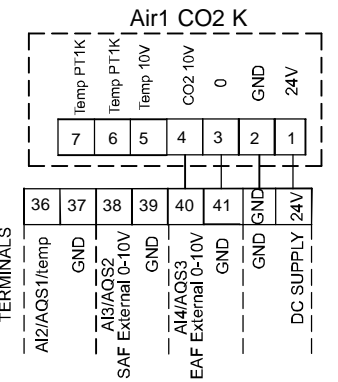

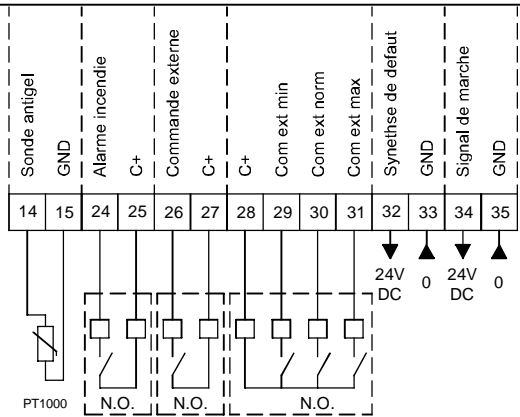

Borniers de raccordement

PT1000

AIR1 CAP

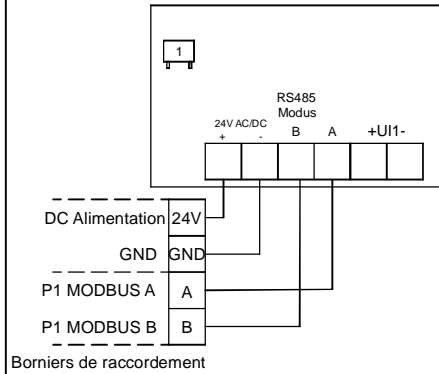

Vanne trois voies batterie de chauffe

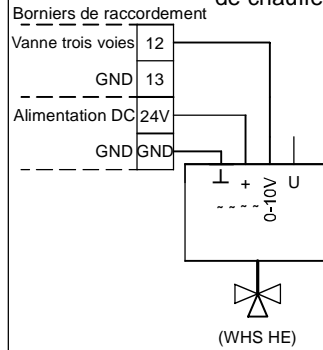

Y3 vanne trois voies batterie eau glatee

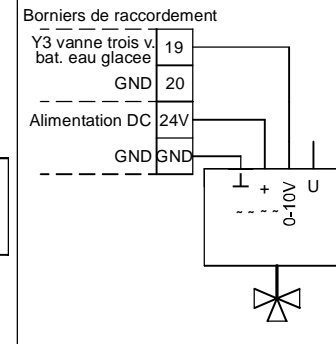

AIR1-BE ECO

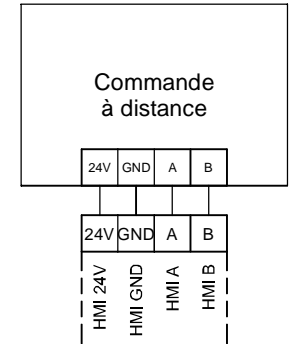

Batterie de post-chauffage electrique

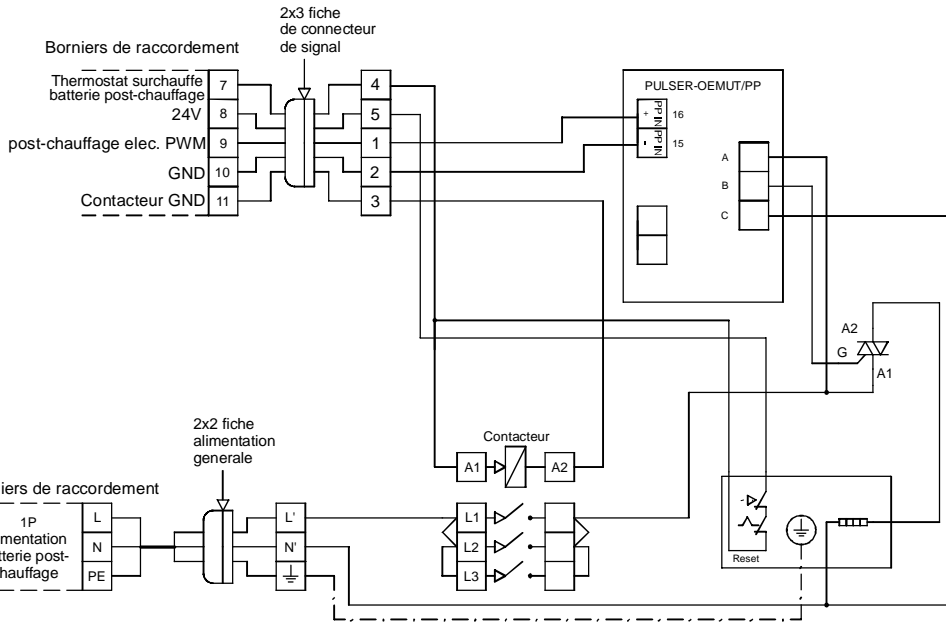

Pompe

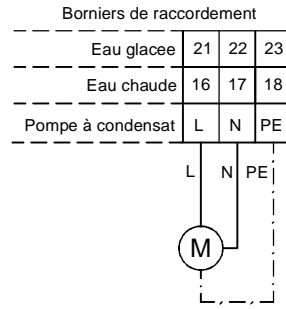

AIR1-BE TOUCH

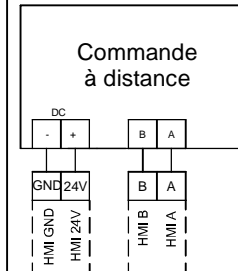

Alimentation generale

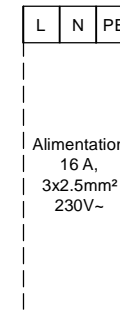

BACNET & MODBUS

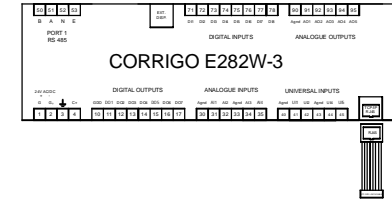

Sondes de qualite d'air

AIR1/KWL-FTF 0-10V

Art.Nr. 20252

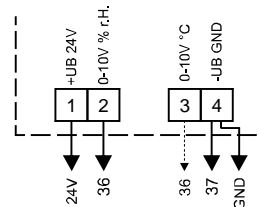

AIR1/KWL-VOC 0-10V

Art.Nr. 20250

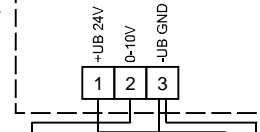

AIR1/KWL-CO2 0-10V

Art.Nr. 20251

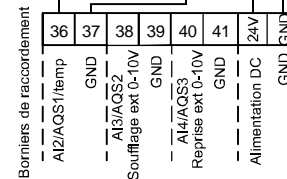
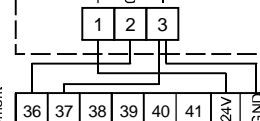

36-37: Sonde de qualite d'air 1 ou capteur de temperature (sortie de temperature AIR1/KWL-FTF 0-10V)

38-39: Sonde de qualite d'air 2

40-41: Sonde de qualite d'air 3

Air1 CO2 K

